

DOOSAN INFRACORE GENERATOR ENGINE

DP126LB

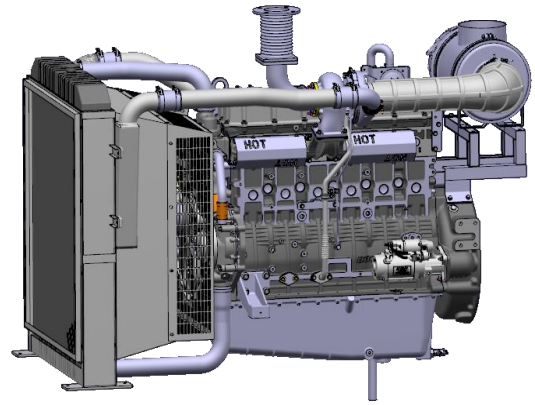

Ratings (kWm/PS)	Gross Engine Output		Net Engine Output	
	Standby	Prime	Standby	Prime
1500rpm(50Hz)	362/492	327/445	346/470	311/423
1800rpm(60Hz)	402/547	366/498	378/514	342/465

Ratings Definitions

The power ratings of Emergency Standby and Prime are in accordance with ISO 8528.

Fuel Stop power in accordance with ISO 3046.

Electric power (kWe) must be considered cooling fan loss, alternator efficiency, altitude derating and ambient temperature.

STANDBY POWER RATING is applicable for supplying emergency power for the duration of the utility power outage.

No overload capability is available for this rating. A standby rated engine should be sized for a maximum of an 80% average load factor and 200 hours of operation per year. This includes less than 25 hours per year at the Standby Power rating.

PRIME POWER RATING is available for an unlimited number of hours per year in variable load application. Variable load should not exceed a 70% average of the Prime Power rating during any operating period of 24 hours. The Total operating time at 100% Prime Power shall not exceed 500 hours per year. A 10% overload capability is available for a period of 1 hour withing a 12 hour period of operation. Total operating time at the 10% overload power shall not exceed 25 hours per year.

◎ GENERAL ENGINE DATA

○ Engine Model	DP126LB
○ Engine Type	4-Cycle, In-line, 6-Cylinder Diesel, water cooled, Turbo charged & intercooled
○ Bore x stroke	123 x 155 mm
○ Displacement	11.051 liters
○ Compression ratio	17.2 : 1
○ Rotation	Counter clockwise viewed from Flywheel
○ Firing order	1-5-3-6-2-4
○ Injection timing	17±1
○ Dry weight	1008 Kg
○ Dimension (LxWxH)	1,426 x 1,096 x 1,295 mm
○ Fly wheel housing	SAE NO.1M
○ Fly wheel	Clutch NO.14M
○ Number of teeth on flywheel	106

◎ ENGINE MOUNTING

Maximum Bending Moment at Rear Face to Block	1325 N · M
--	------------

◎ EXHAUST SYSTEM

Maximum Back Pressure	5.9 kPa
-----------------------	---------

◎ AIR INDUCTION SYSTEM

Maximum Intake Air Restriction	
. With Clean Filter Element	2.16 kPa
. With Dirty Filter Element	6.23 kPa
○ Max. static pressure after Radiator	0.125 kPa

◎ COOLING SYSTEM

Water circulation by centrifugal pump on engine.

○ Cooling method	Fresh water forced circulation
○ Coolant capacity	Engine Only : Approx. 23 lit., With Radiator : Approx.51 lit.(standard)
○ Coolant flow rate	540 liters / min
○ Pressure Cap	90 kPa
○ Water Temperature	
- Maximum for standby and Prime	110°C
- Before start of full load	40.0°C
○ Water pump	Centrifugal type driven by Pulley
○ Thermostat Type and Range	Wax – pellet type, Opening temp. 82°C , Full open temp. 95°C
○ Cooling fan	Blower type, Plastic , 810 mm diameter, 7 blade
○ Max. external coolant system restriction	Not Available

◎ LUBRICATION SYSTEM

Force-feed lubrication by gear pump, lubricating oil cooling in cooling water circuit of engine.

○ Lub. Method	Fully forced pressure feed type
○ Oil pump	Gear type driven by crank-shaft gear
○ Oil filter	Full flow, cartridge type
○ Oil capacity	Max. 44 liters , Min. 20 liters
○ Lub oil pressure	Idle Speed : Min 100 kPa Governed Speed : Min 300 kPa
○ Maximum oil temperature	120°C
○ Angularity limit	Front down 10 deg , Front up 10 deg , Side to side 22.5 deg
○ Lubrication oil	Refer to Operation Manual

◎ FUEL SYSTEM

Bosch type in-line pump with integrated, electromagnetic actuator.

○ Injection pump	WEIFU In-line "P" type
○ Governor	Electric type (all speed control)
○ Speed drop	G2 Class (ISO 8528)
○ Feed pump	Double action plunger type pump on injection pump
○ Injection nozzle	Multi hole type
○ Opening pressure	30 MPa
○ Fuel filter	Main(On Engine) : Full flow, High efficiency dust in fuel filter, cartridge Pre(Loosed Part) : Full flow, cartridge type with water drain valve
○ Maximum fuel inlet restriction	10 kPa
○ Maximum fuel return restriction	60 kPa
○ Fuel feed pump Capacity	315 liters / hr
○ Used fuel	Diesel fuel oil

◎ ELECTRICAL SYSTEM

○ Battery Charging Alternator	24V x 80A alternator
○ Voltage regulator	Built-in type IC regulator
○ Starting motor	24V x 6.0 kW
○ Battery Voltage	24V
○ Battery Capacity	200 Ah (recommended)
○ Starting aid (Option)	Block heater, Air heater

◎ VALVE SYSTEM

○ Type	Overhead valve type	
○ Number of valve	Intake 2, exhaust 2 per cylinder	
○ Valve lashes at cold	Intake 0.4mm , Exhaust 0.5mm	
○ Valve timing		
	Opening	Close
- Intake valve	24 deg. BTDC	38 deg. ABDC
- Exhaust valve	62 deg. BBDC	25 deg. ATDC

◎ PERFORMANCE DATA

		Prime Power		Standby Power	
○ Governed Engine speed	rpm	1500	1800	1500	1800
○ Engine Idle Speed	rpm	800	800	800	800
○ Over speed limit	rpm	1650	1980	1650	1980
○ Gross Engine Power Output	kW	327	366	362	402
	ps	445	498	492	547
○ Break Mean effective pressure	Mpa	2.37	2.21	2.62	2.43
○ Mean Piston Speed	m/s	7.75	9.3	7.75	9.3
○ Friction Power	kW	26.3	38.4	26.3	38.4
	ps	35.7	52.2	35.7	52.2
○ Specific fuel consumption					
25% load	liters/hr	20.2	24.0	22.1	26.1
50% load	liters/hr	38.4	43.4	42.5	47.3
75% load	liters/hr	57.1	64.0	63.1	70.1
100% load	liters/hr	76.0	85.8	84.5	96.4
○ Fan Power	kW	16	24	16	24
○ Sound Pressure at 1m from the each side of Cylinder Block (without Fan)	dB(A)	99.5	100.4	99.5	100.5

The all data and the specific fuel consumption are based on ISO 3046/1, Standard reference conditions are in accordance with 298 K(25° Celsius) air temperature, 100kPa(1000mbar) air pressure, 60% relative humidity, 110m(361ft) altitude.

Engine Data with Dry Type Exhaust Manifold

○ Intake Air Flow	m3/min	19.0	25.4	20.9	27.0
○ Exhaust gas temp. after turbo.	°C	575.0	505.0	590.0	535.0
○ Exhaust Gas Flow	m3/min	52.9	62.1	58.3	67.6
○ Heat Rejection to Exhaust	kW	253.3	290.8	279.3	324.6
○ Heat Rejection to Coolant	kW	92.4	102.7	114.0	125.4
○ Heat Rejection to Intercooler	kW	46.7	57.6	73.4	87.1
○ Radiated Heat to Ambient	kW	43.0	43.0	32.0	33.0
○ Cooling water circulation	liters/min	435	525	435	525
○ Cooling fan air flow	m3/min	312	528	312	528

◆ ENGINE DIMENSION

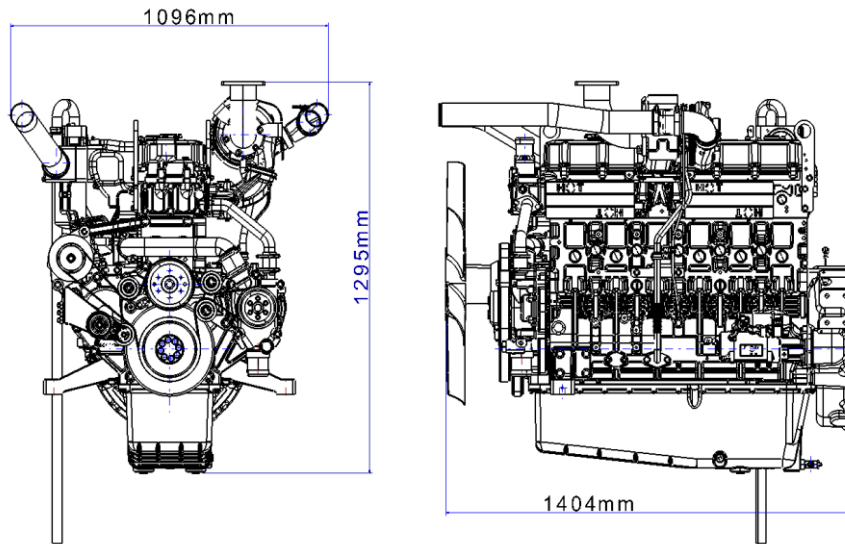

◆ CONVERSION TABLE

in. = mm x 0.0394

PS = kW x 1.3596

psi = kg/cm² x 14.2233

in³ = lit. x 61.02

hp = PS x 0.98635

lb = kg x 2.20462

kW = Kcal/sec x 0.239

lb/ft = N.m x 0.737

U.S. gal = lit. x 0.264

kW = 0.2388 kcal/s

lb/PS.h = g/kW.h x 0.00162

cfm = m³/min x 35.336

Mpa = Pa x 1000 = bar x 10

Doosan Infracore Co., Ltd.

21st Floor, Doosan Tower, 18-12, Euljiro 6-ga,
Jung-gu, Seoul, Korea.

TEL : +82-2-3398-8400 / FAX : +82-2-3398-8509

E-mail : enginesales@doosan.com

Web site : www.doosaninfracore.com

※ Specifications are subject to change without prior notice