

1100 Series 1106A-70TAG2 Diesel Engine – Electropak

144.1 kWm net power @ 1500 rpm

Building upon Perkins proven reputation within the power generation industry, the 1100 Series range of Electropak engines now fit even closer to customers needs.

In the world of power generation success is only gained by providing more for less. With the 1106A-70TAG Perkins has engineered even higher levels of reliability, yet lowered the cost of ownership.

1100A units are designed for territories that do not require compliance to EPA or EU emissions legislation. These engines are assembled around optimal, efficient manufacturing processes with state-of-the-art technology. They are built to provide the exact power solution for customers who sell their applications into lesser regulated countries.

Focusing on our common platform theme, changes to engine envelope dimensions and connection points have been kept to a minimum.



Specification		
Number of cylinders	6 vertical in-line	
Bore and stroke	105 x 135 mm	4.13 x 5.31 in
Displacement	7.01 litres	428 in ³
Aspiration	Turbocharged aftercooled	
Cycle	4 stroke	
Combustion system	Direct injection	
Compression ratio	16:1	
Rotation	Anti-clockwise, viewed on flywheel	
Total lubricating capacity	16.5 litres	4.36 US gal
Cooling system	Liquid	
Total coolant capacity	21 litres	5.5 US gal

www.perkins.com

Photographs are for illustrative purposes only and may not reflect final specification. All information in this document is substantially correct at time of printing and may be altered subsequently. Final weight and dimensions will depend on completed specification.

Publication No. PN3054A/12/14 Produced in England ©2014 Perkins Engines Company Limited

 **Perkins**[®]

THE HEART OF EVERY GREAT MACHINE

1100 Series 1106A-70TAG2 Diesel Engine – ElectropaK

144.1 kWm net power @ 1500 rpm

Features and benefits

Dependable power

- The Perkins® 1106A-70TAG2 delivers up to 165 kVA standby at 50 Hz and 150 kWe standby at 60 Hz, providing greater productivity through an improved power to weight ratio
- This world-class power density has been achieved in a 7 litre engine, using a mechanical fuel injection system; making this engine robust for all markets, with the ability to cope with the variation of fuel qualities around the world
The 1106A has been designed for excellent load acceptance to ensure your facility is powered quickly at all conditions

Low operating costs

- Service intervals are set at 500 hours as standard
- **Warranties and Service Contracts**
We provide one-year warranties for constant speed engines and two-year warranties for variable speed models, as standard. These are supported by multilevel Extended Service Contracts that can be bought additionally
Discover more: www.perkins.esc
- Low usage warranty package is also available

World class product support

- Through an experienced global network of distributors and dealers, fully trained engine experts deliver total service support around the clock, 365 days a year. They have a comprehensive suite of web based tools at their finger tips, covering technical information, parts identification and ordering systems, all dedicated to maximising the productivity of your engine
- Perkins actively pursues product support excellence by insisting our distribution network invest in their territory to provide you with a consistent quality of support across the globe
- Throughout the entire life of a Perkins engine, we provide access to genuine OE specification parts giving 100% reassurance that you receive the very best in terms of quality for lowest possible cost... wherever your Perkins powered machine is operating in the world
- To find your local distributor: www.perkins.com/distributor

www.perkins.com

Photographs are for illustrative purposes only and may not reflect final specification.
All information in this document is substantially correct at time of printing and may be altered subsequently.
Final weight and dimensions will depend on completed specification.

Publication No. PN3054A/12/14 Produced in England ©2014 Perkins Engines Company Limited

 **Perkins®**

THE HEART OF EVERY GREAT MACHINE

1100 Series 1106A-70TAG2 Diesel Engine – ElectropaK

144.1 kWm net power @ 1500 rpm

Technical information

- Tropical radiator pipes and guards
- Flywheel housing
- Flywheel and starter ring
- Oil filters
- Starter motor
- Air cleaners and brackets
- Lubricating oil sump
- Alternator
- Induction manifolds
- Exhaust manifolds
- Fuel filter
- Cold start aid
- Engine mountings

www.perkins.com

Photographs are for illustrative purposes only and may not reflect final specification.
All information in this document is substantially correct at time of printing and may be altered subsequently.
Final weight and dimensions will depend on completed specification.

Publication No. PN3054A/12/14 Produced in England ©2014 Perkins Engines Company Limited

 **Perkins**[®]

THE HEART OF EVERY GREAT MACHINE

1100 Series 1106A-70TAG2 Diesel Engine – Electropak

144.1 kWm net power @ 1500 rpm

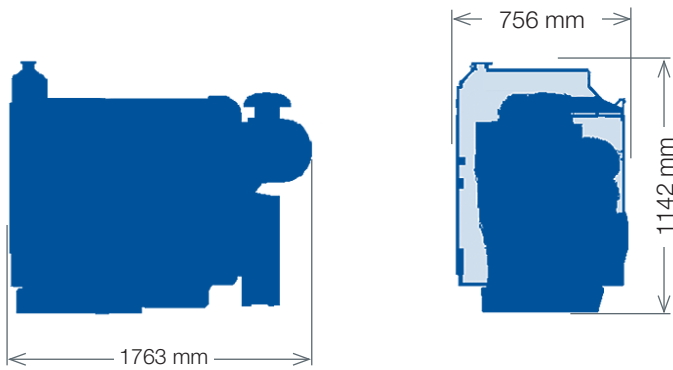

Engine package weights and dimensions

Engine package weights and dimensions		
Length with air cleaner	1763 mm	69.4 in
Width	756 mm	29.8 in
Height	1142 mm	145 in
Weight (dry)	788 kg	1737 lb

www.perkins.com

Photographs are for illustrative purposes only and may not reflect final specification.
All information in this document is substantially correct at time of printing and may be altered subsequently.
Final weight and dimensions will depend on completed specification.

Publication No. PN3054A/12/14 Produced in England ©2014 Perkins Engines Company Limited

 **Perkins**[®]

THE HEART OF EVERY GREAT MACHINE

1100 Series 1106A-70TAG2 Diesel Engine – Electropak

144.1 kWm net power @ 1500 rpm

Speed rpm	Type of operation	Typical generator output (Net)		Engine power			
				Gross		Net	
		kVA	kWe	kWm	hp	kWm	hp
1500	Prime power	150	120	136.0	182.4	131.0	175.7
	Standby (maximum)	165	132	153.6	206.0	144.1	193.2

Percent of prime power	Fuel consumption at 1500 rpm g/kWh	Fuel consumption at 1500 rpm l/hr
110%	201.1	36.1
Prime power	203.3	33.4
75%	199.7	24.7
50%	197.9	16.4
25%	221.1	9.1